

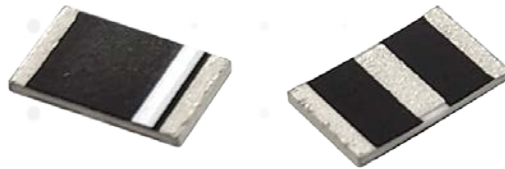

SPECIFICATION

**ISM band – 433 MHz
Chip Antenna**



Model No. : UTCLW-401



1. General Description

1.1 Electrical Properties

Parameter		Description
Frequency Band		431.8~433.7 MHz
Nominal Impedance		50 Ω
Polarization		Linear
V.S.W.R.		<2:1
Efficiency	@ 433 MHz	12 %
Peak Gain		-7.3 dBi
※With 80 x 40 mm Evaluation Board		

1.2 Mechanical Properties

Parameter	Description
Dimensions	5*3*0.5 mm
Operating Temperature	-40°C~85°C
Storage Temperature (With Packing Sealed)	-5°C~40°C

2. Appearance

2.1 Dimensions Of Antenna And Evaluation Board (Unit : mm)

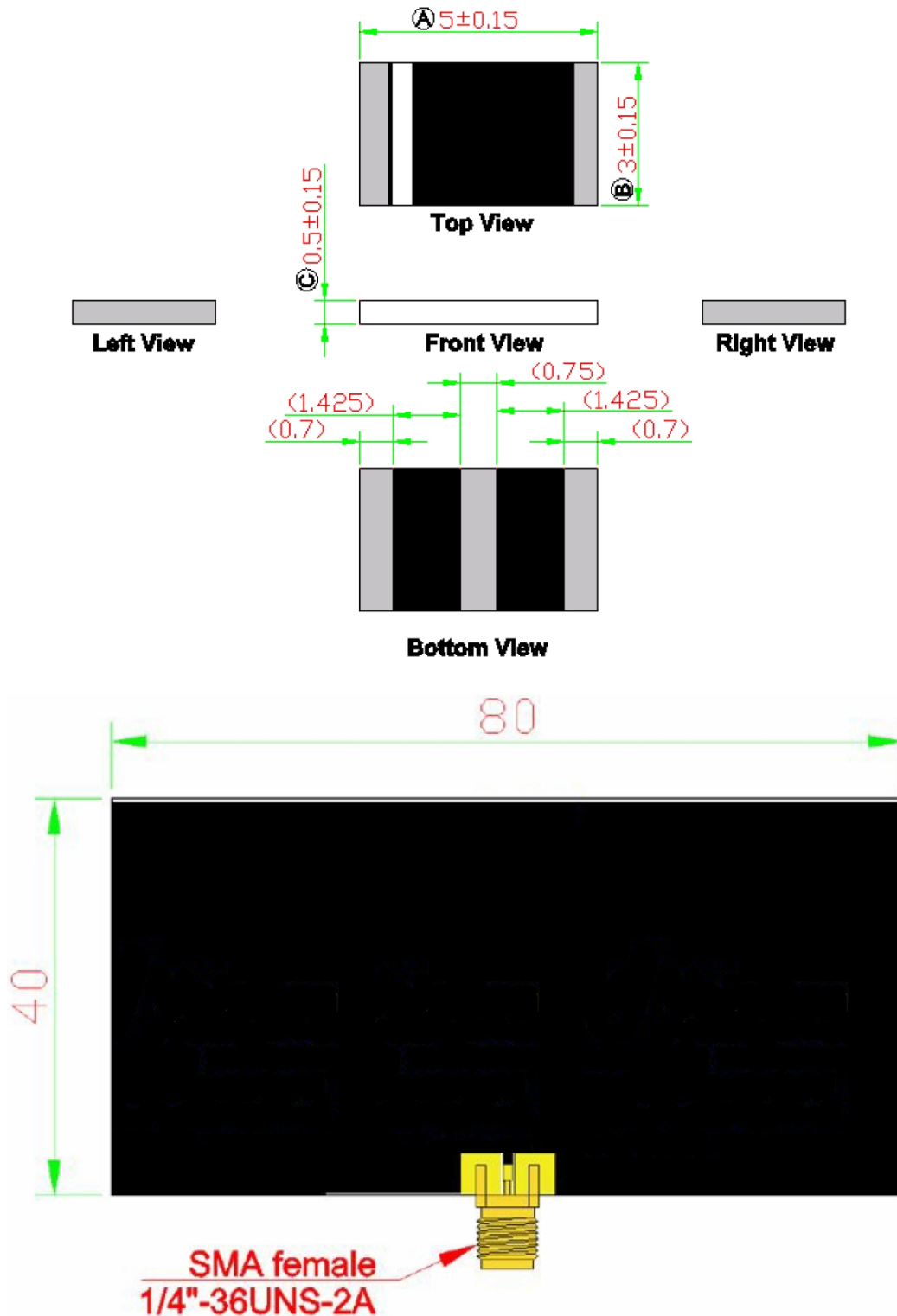

2.2 PIN Definitions

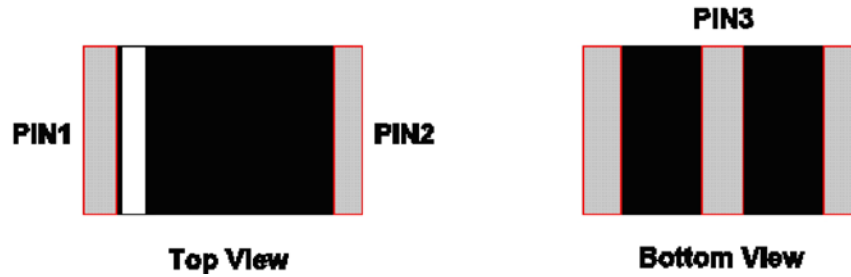

Item	PIN 1	PIN 2	PIN 3
Terminal	Signal	Tuning / Ground	Soldering Pad

3. Layout Guide (Unit : mm)

The solder land pattern (gray marking areas) is shown as below.
 Recommendation on matching circuit will be provided according to customer's installation conditions.

With 80 x 40 mm Evaluation Board

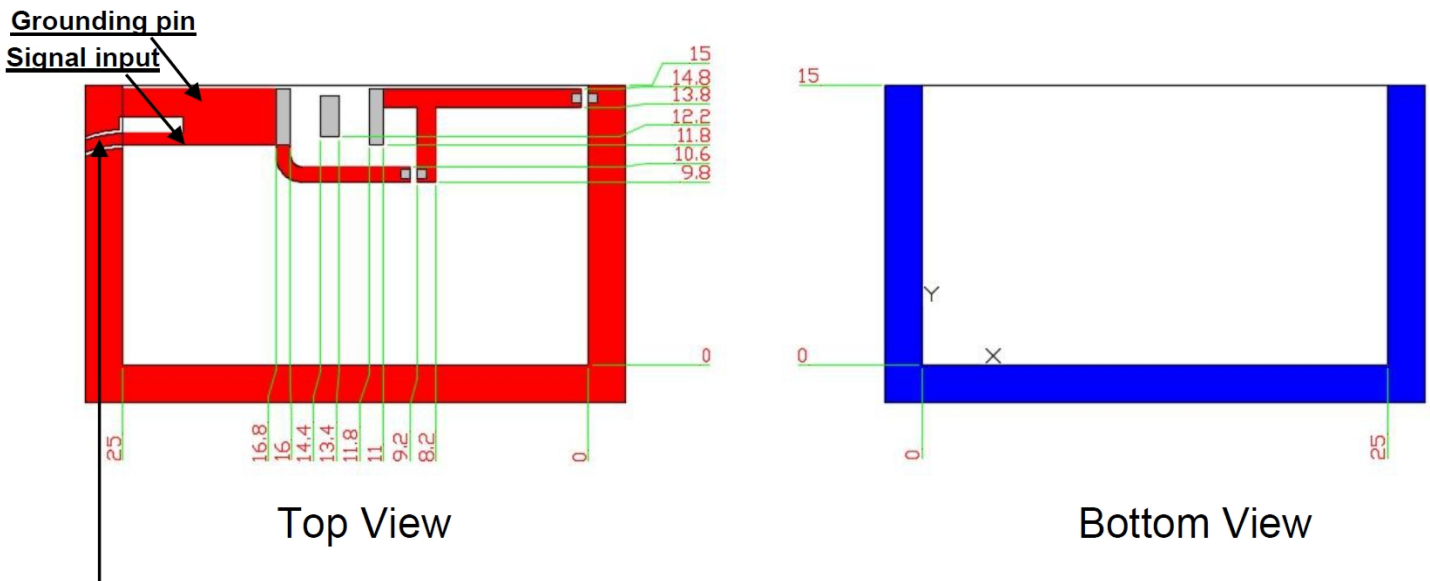

Transmission Line with 50Ω Impedance Characteristic

4. Frequency Tuning And Matching Circuit

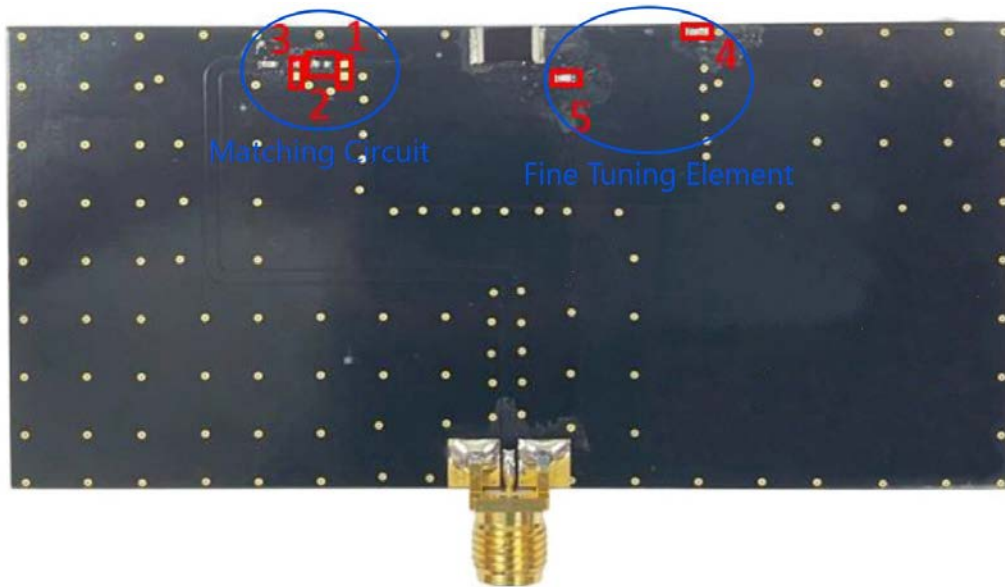

With the following recommended values of matching and tuning components, the center frequency will be about 433 MHz at our standard 80x40 mm evaluation board.

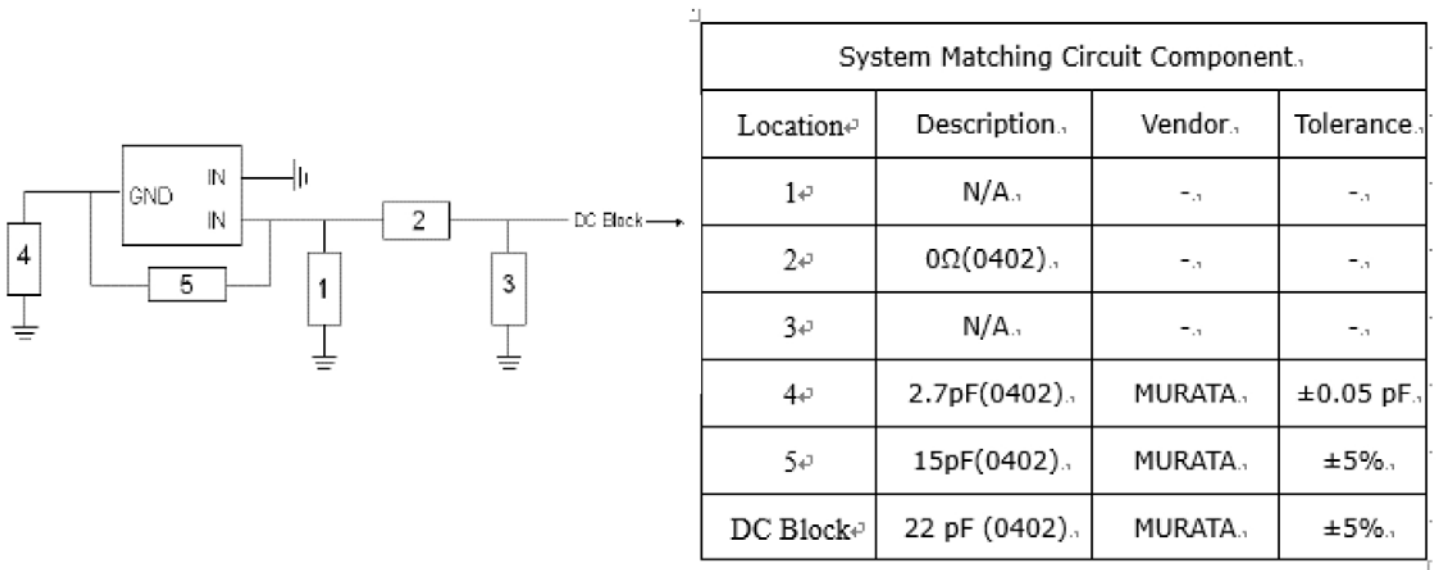

※These are typical reference values which may need to be changed when circuit boards or part vendors are different.

5. Soldering Conditions

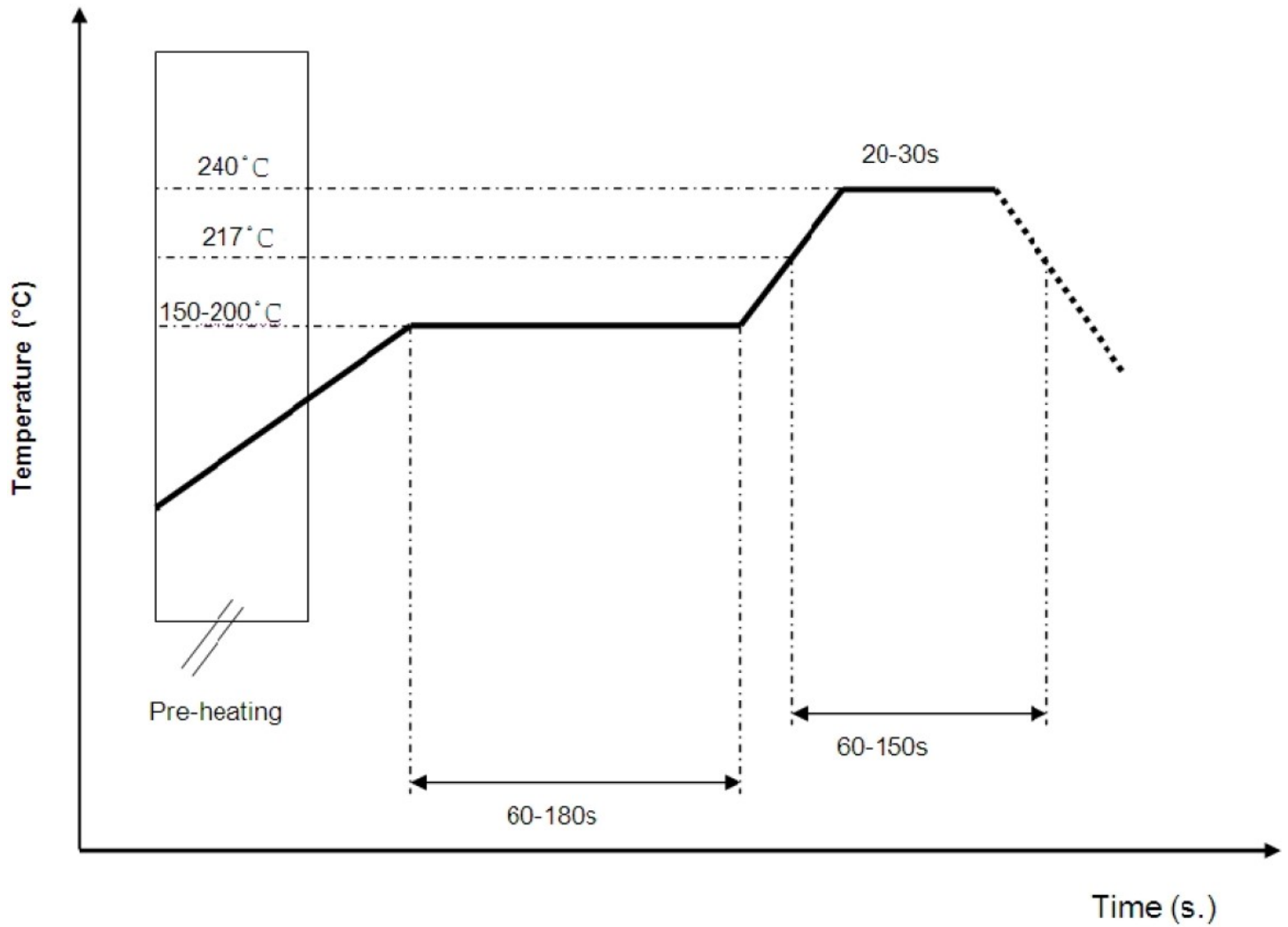

※Recommended solder paste alloy : SAC305(Sn96.5/Ag3/Cu0.5) Lead free solder paste.



6. Performance

6.1 Return Loss & V.S.W.R.

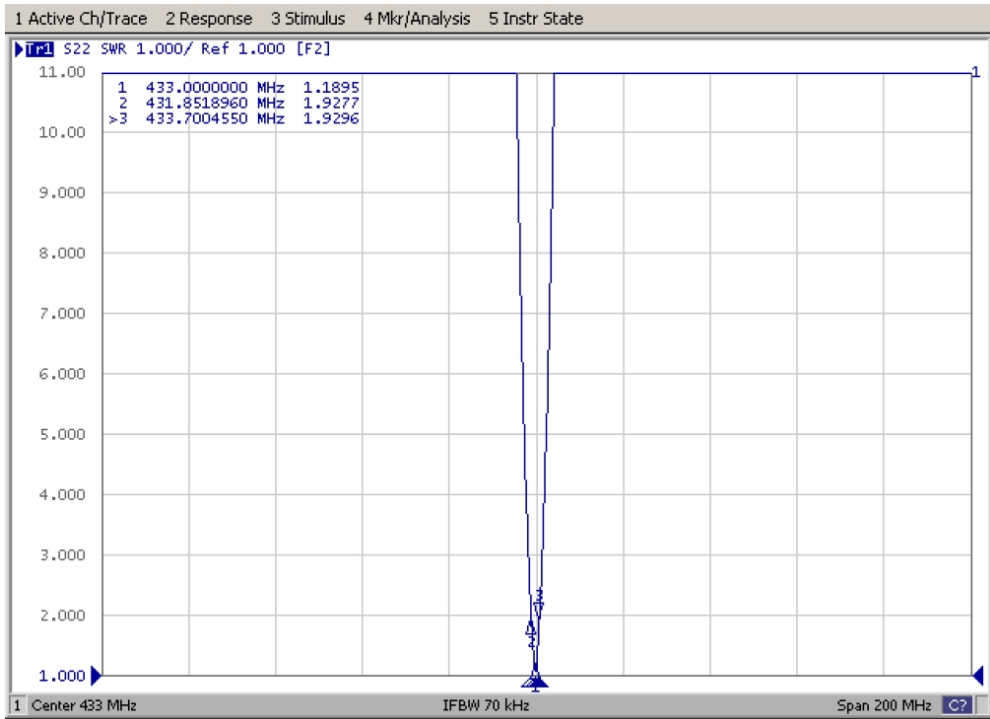
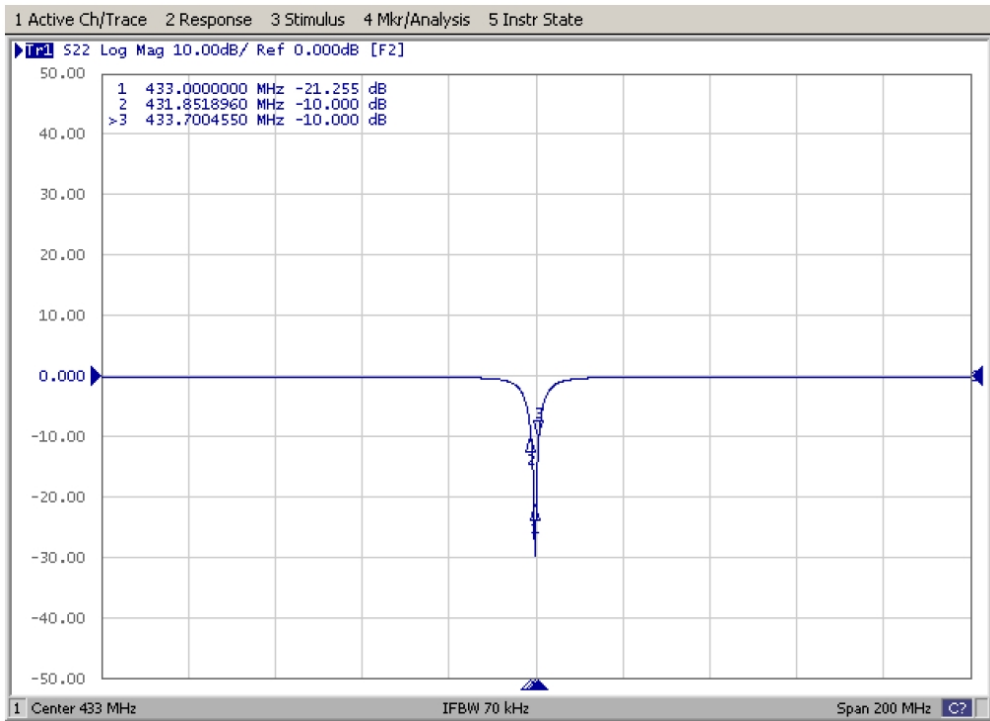



6.2 Efficiency & Peak Gain

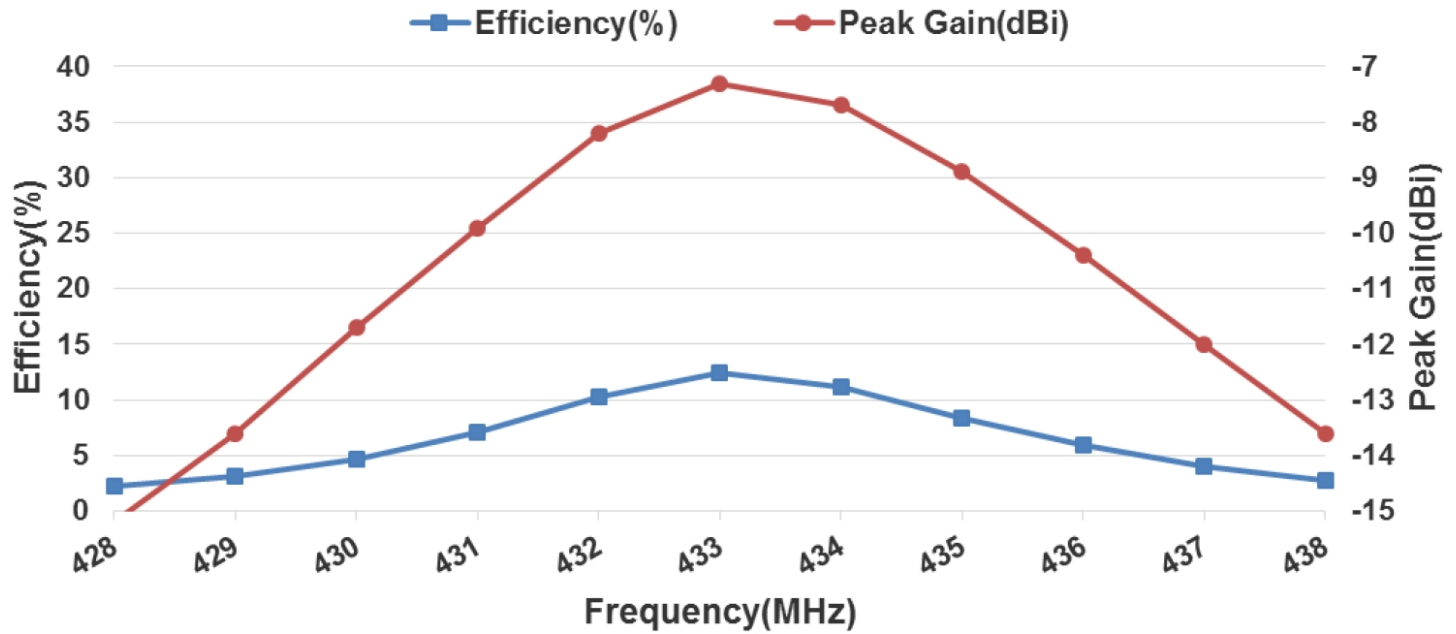

Frequency (MHz)	428	429	430	431	432	433	434	435	436	437	438
Efficiency (dB)	-16.7	-15.1	-13.3	-11.5	-9.9	-9.1	-9.5	-10.8	-12.3	-14	-15.6
Efficiency (%)	2.2	3.1	4.7	7.1	10.3	12.4	11.2	8.4	5.9	4	2.7
Peak Gain (dBi)	-15.2	-13.6	-11.7	-9.9	-8.2	-7.3	-7.7	-8.9	-10.4	-12	-13.6

6.3 3D Radiation Pattern

3D Gain Pattern @ 433 MHz (Unit : dBi)

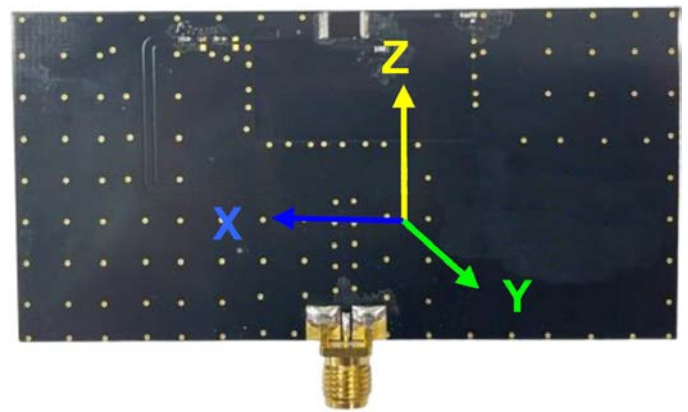
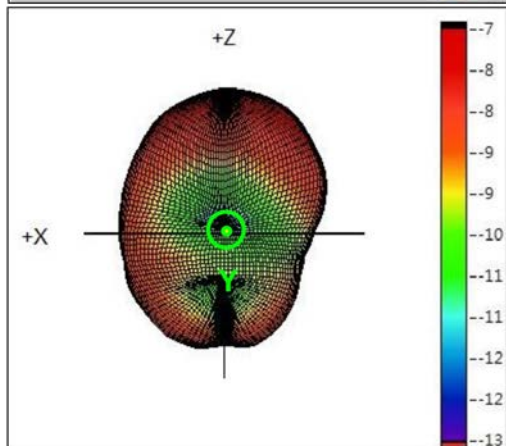
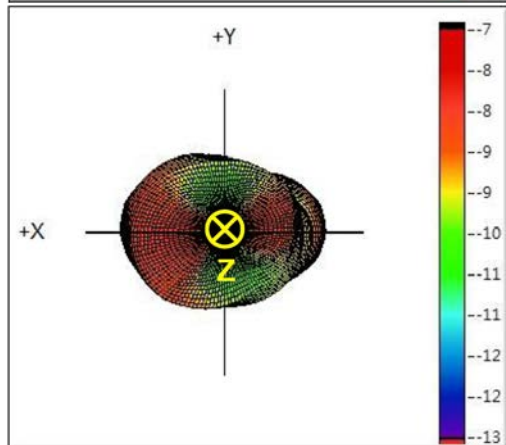
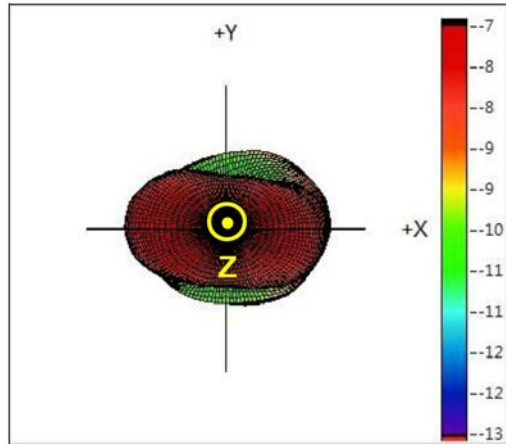

7. Packing

- Tape :

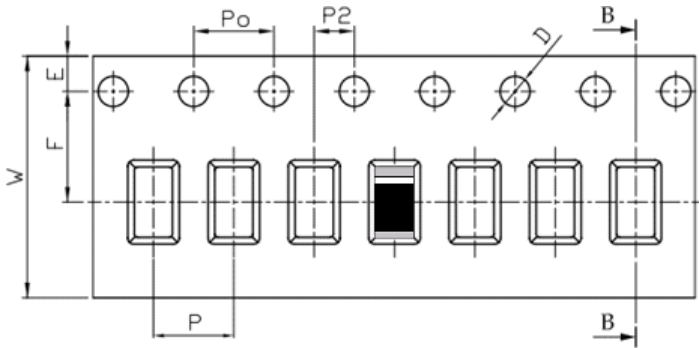

Feature	Specifications	Tolerances
W	12.00	±0.30
P	4.00	±0.10
E	1.75	±0.10
F	5.50	±0.10
P2	2.00	±0.10
D	1.50	+0.10 -0.00
Po	4.00	±0.10
10Po	40.00	±0.20

- Reel : 6,000 pcs

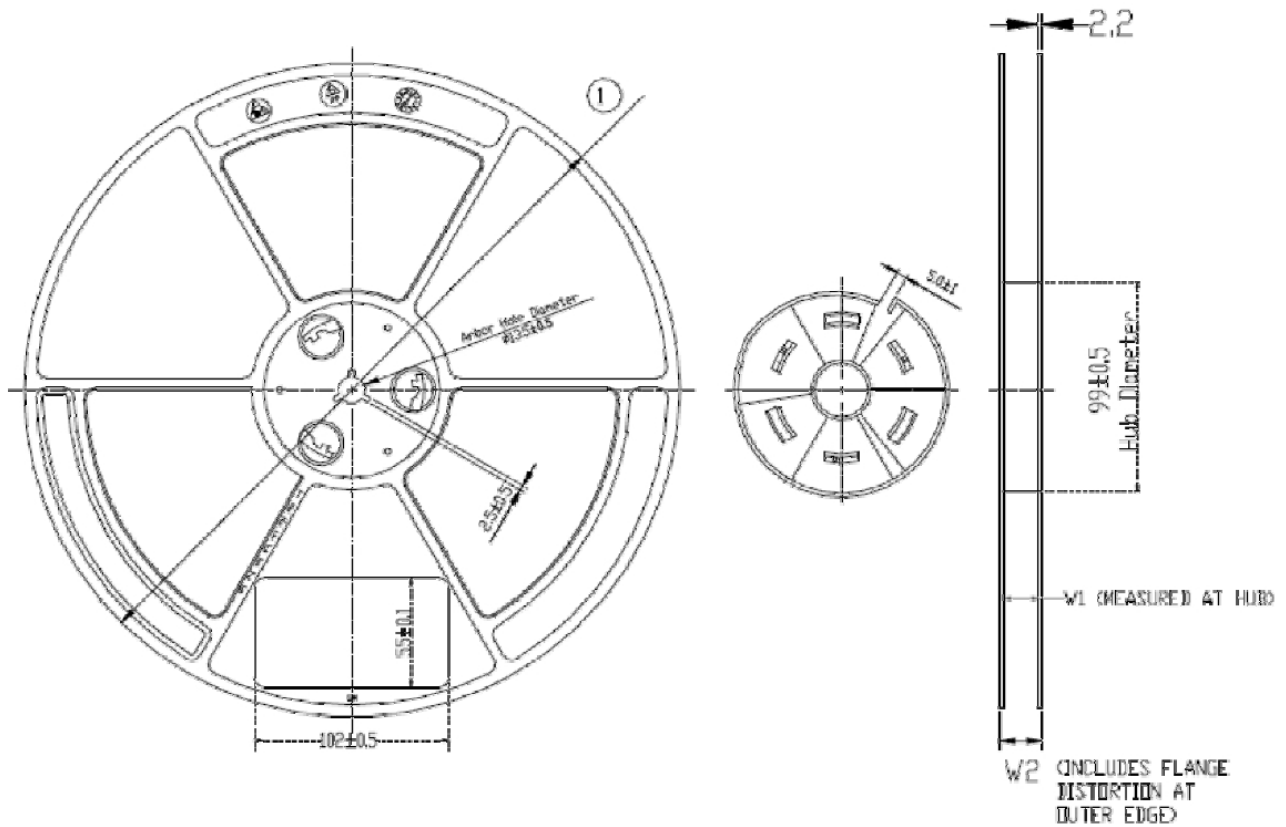

① Diameter	W1	W2
330±1mm	13.4±1mm	17.8±1mm