



# SPECIFICATION

**ISM band – 868 MHz  
Stubby Antenna**



**Model No. : AB05LW-8-S0**



---

## 1. General Description

### 1.1 Electrical Properties

Parameter	Description
Frequency Band	868 MHz
Nominal Impedance	50 $\Omega$
Polarization	Vertical
V.S.W.R.	<2 : 1

### 1.2 Mechanical Properties

Parameter	Description
Dimensions	28 mm $\pm$ 0.5
Connector	180° SMA Male
Operating Temperature Range	-20°C~60°C
Storage Temperature Range	-30°C~70°C

## 2. Appearance (Unit : mm)

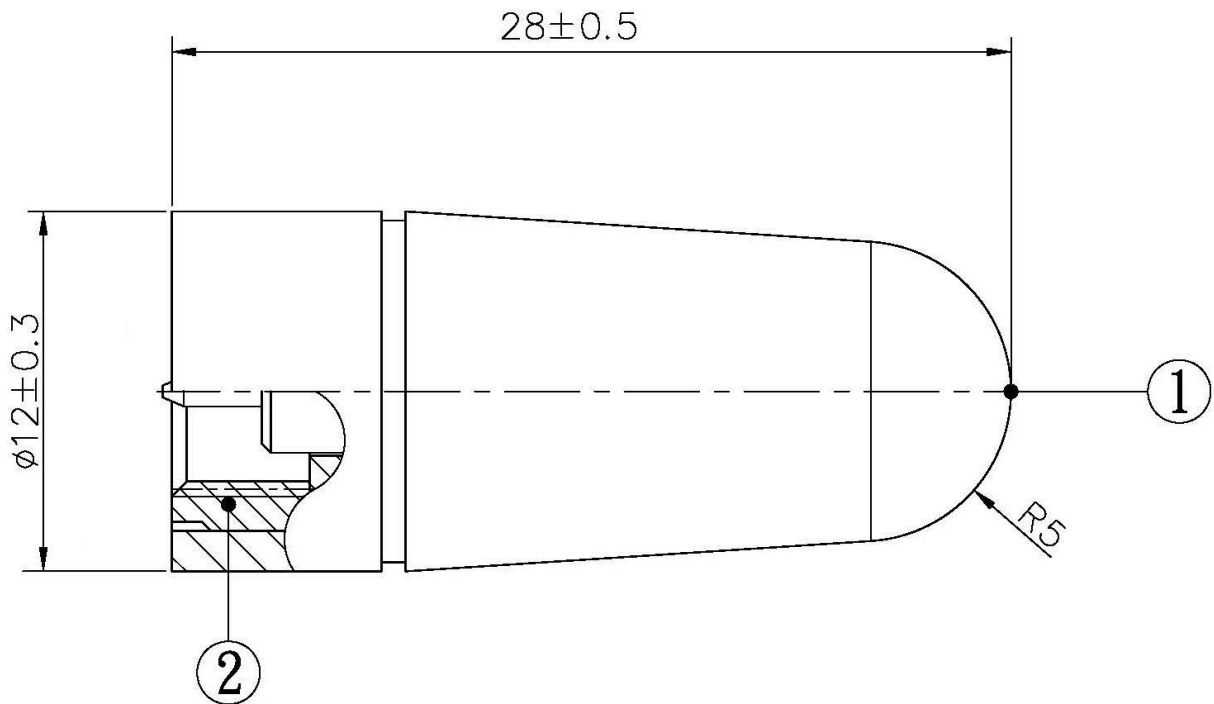

NO.	Name	Finish
1	Tube covering	Black
2	180° SMA Male	Gold plating



### 3. Performance

#### Return Loss

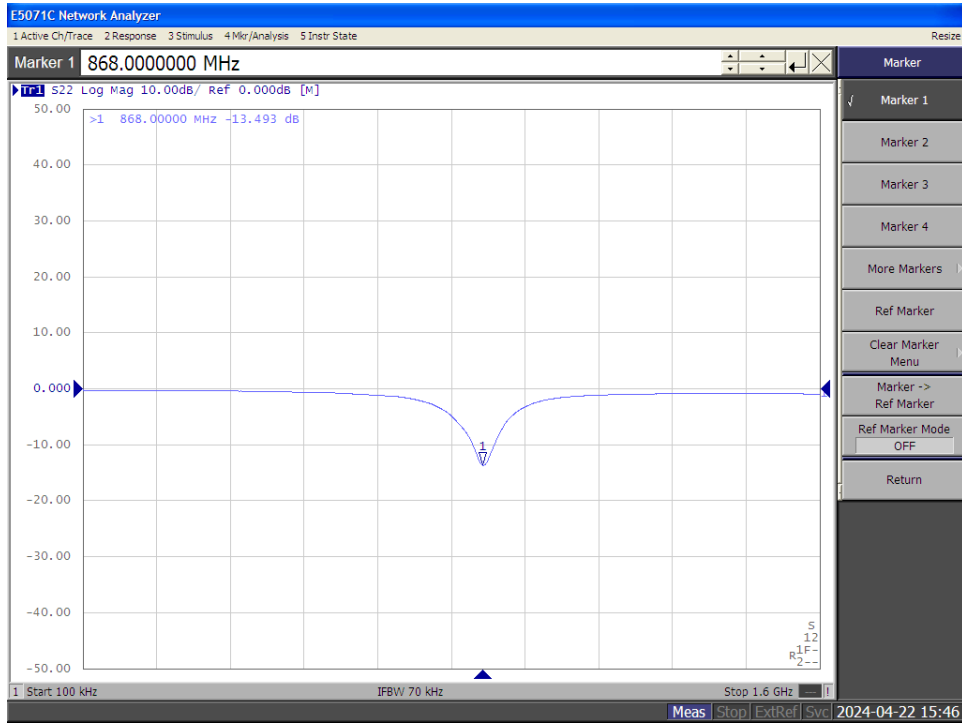

#### V.S.W.R.

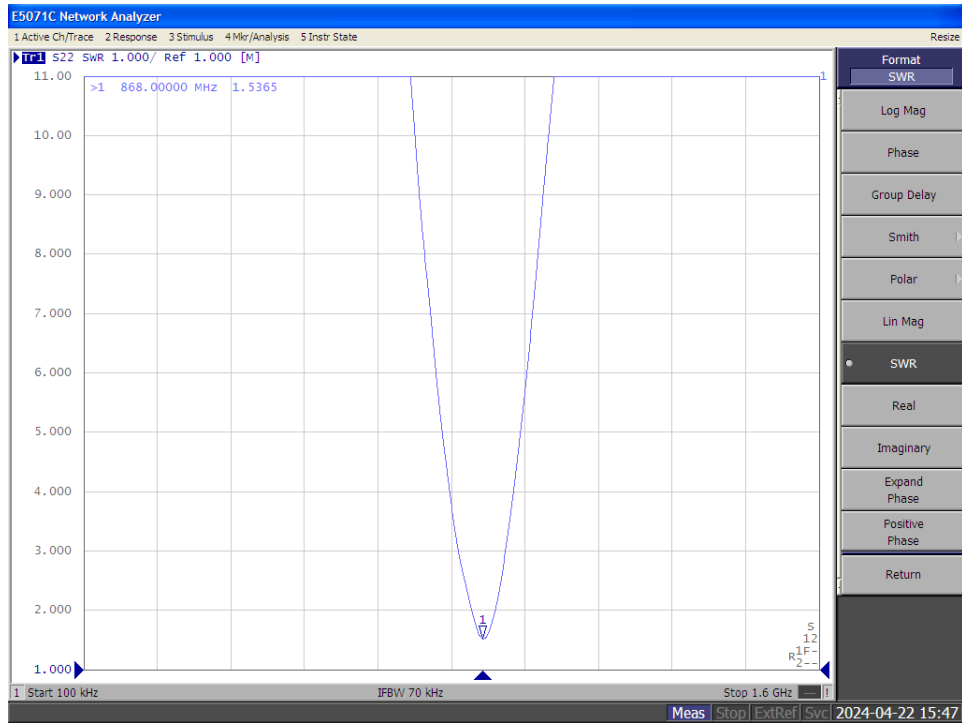

## Smith Chart

