



SPECIFICATION

3G / 4G LTE / 5G NR
Adhesive Antenna



Model No. : AA03N1-58-2-S0



1. General Description

1.1 Electrical Properties

Parameter	Description
Frequency Band	617~2700/3300~5850 MHz
Nominal Impedance	50 Ω
V.S.W.R.	<2.5 : 1

1.2 Mechanical Properties

Parameter	Description
Dimensions	115.1*55.5*9.4 mm
Connector	180° SMA Male
Cable Length	RG-58 cable*2000 mm \pm 30
Operating Temperature Range	-20°C~+60°C
Storage Temperature Range	-30°C~+70°C

2. Appearance (Unit : mm)

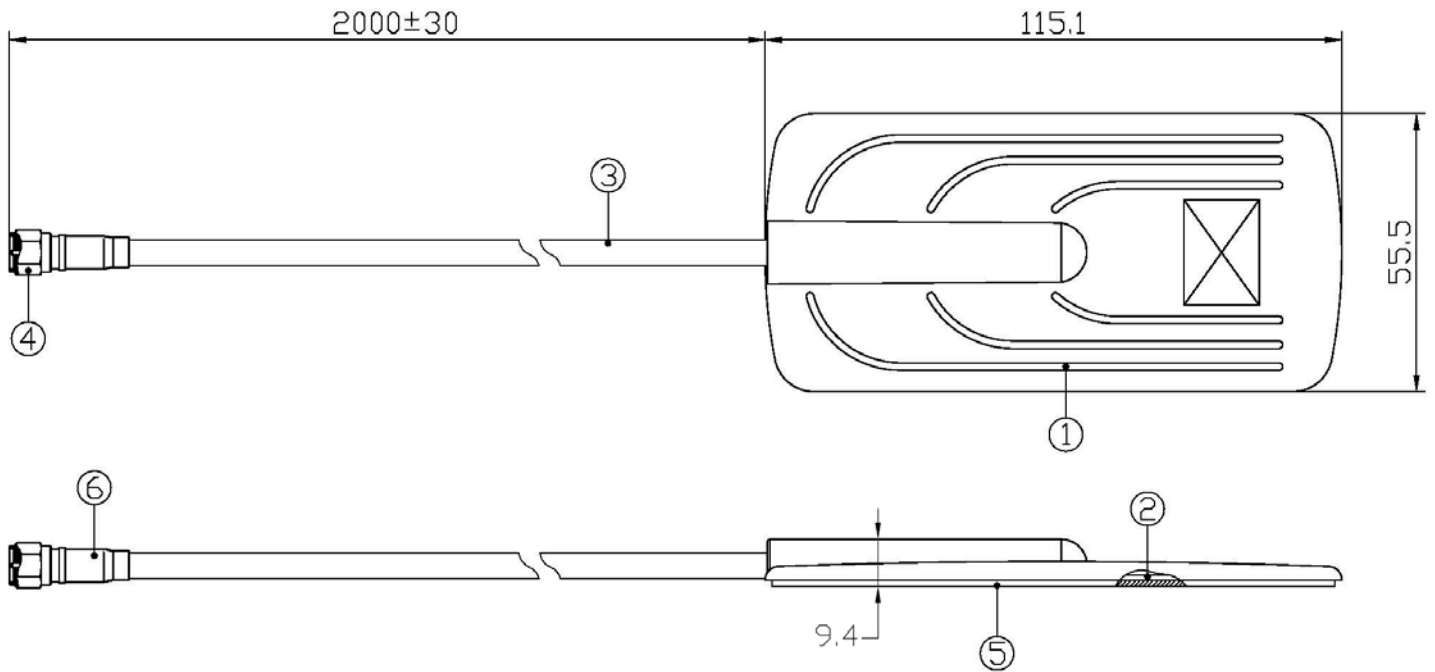

NO.	Name	Finish
1	Top shell	Black
2	PCB	
3	RG-58 A/U cable	Black
4	180° SMA Male	Nickel plating
5	Double-sided adhesive	Gray
6	Heat shrink tube	Black



3. Performance

Return Loss

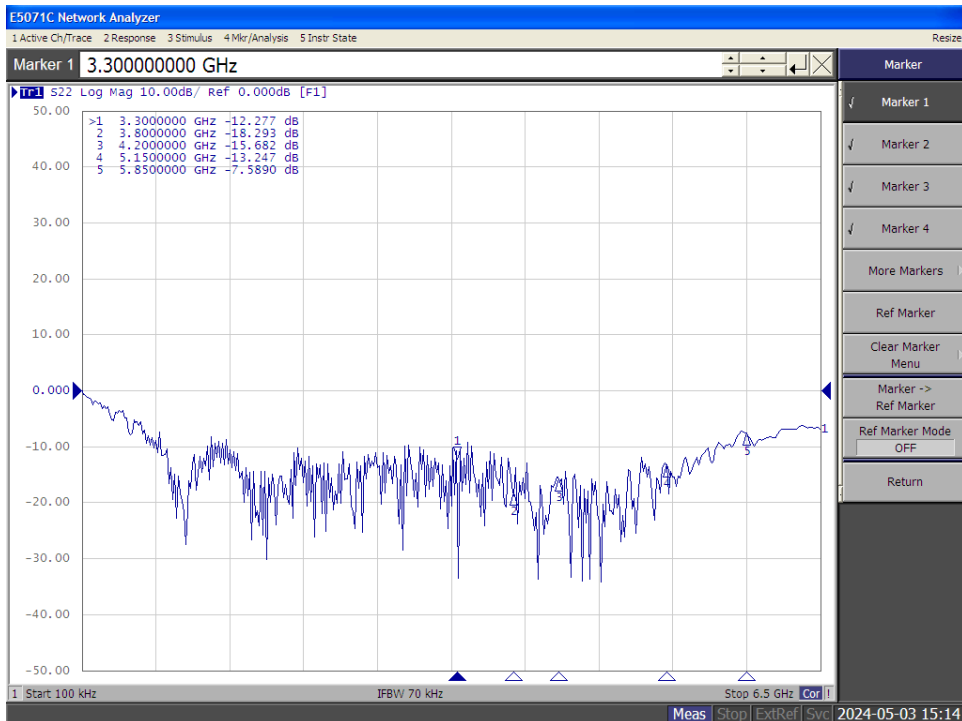
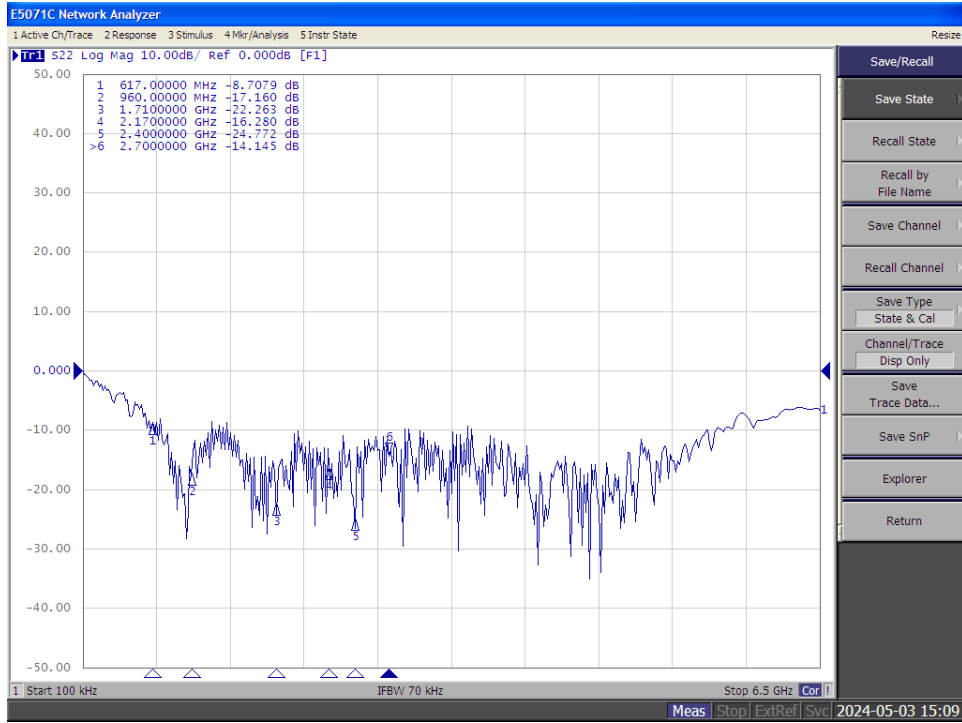



V.S.W.R.

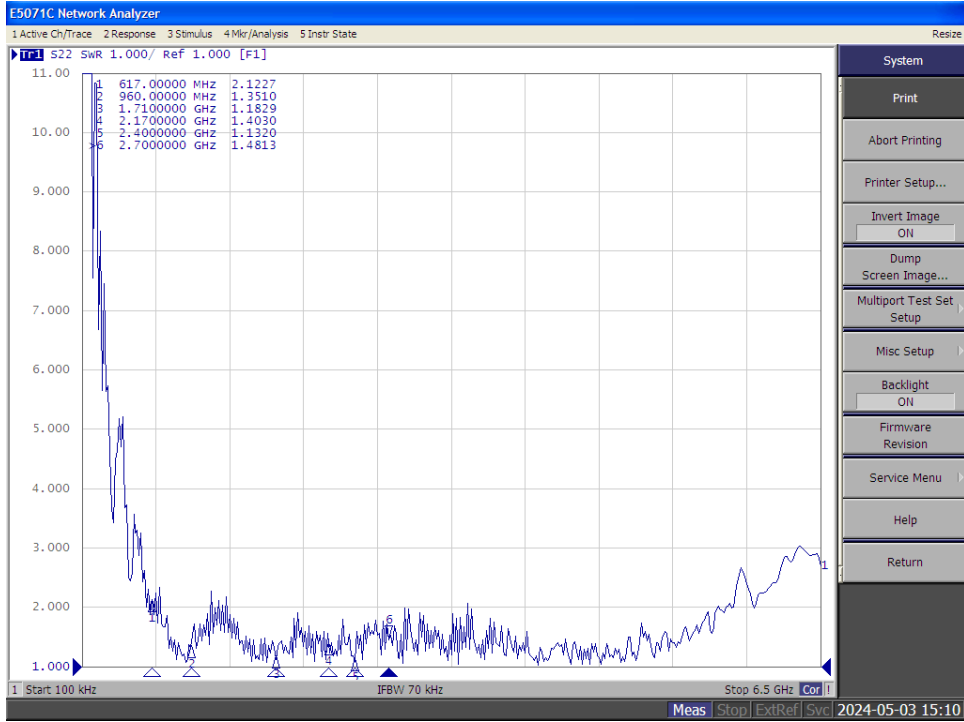



Smith Chart

